

MC BOX



**CONTROL PANEL
FOR DISPENSERS**

***USE AND
MAINTENANCE MANUAL***

ENGLISH

TABLE OF CONTENTS

A. DECLARATION OF CONFORMITY	4	H. INSTALLATION	10
B. FIRST AID RULES	5	H.1 GENERAL	10
C. GENERAL	5	H.2 ELECTRICAL CONNECTIONS..	10
D. SAFETY INSTRUCTIONS	6	I. COMMISSIONING	16
D.1 SAFETY RULES	6	I.1 ELECTRICAL POWER SUPPLY..	16
D.2 TRANSPORT, HANDLING AND UNPACKING	7	I.2 STATION CONFIGURATION	16
D.3 DISPOSAL	7	I.3 DISENGAGING THE "MC" SYSTEM	17
E. USING AND LOOKING AFTER THE MANUALS	8	I.4 METER CALIBRATION	18
E.1 IDENTIFICATION PLATE	8	L. EVERY DAY USE	18
F. DESCRIPTION OF MAIN PARTS ..	9	L.1 FUEL DISPENSING	19
F.1 CONTROL SYSTEM	10	M.ROUTINE MAINTENANCE	20
G. TECHNICAL SPECIFICATIONS	10	M.1 "MC" CONTROL SYSTEM	20
G.1 PERMITTED USES	10	M.2 TROUBLESHOOTING	20
G.2 CONTROL SYSTEM PERFORMANCE	10	N. SPECIAL MAINTENANCE	22
G.2 METERING PRECISION.....	10	N.1 CHECKING AND REPLACING FUSES	22
G.3 ABSORBED POWER	10	O. MC BOX SPARE PARTS	23
		P. MANUFACTURER AND SERVICE DATA	23

DECLARATION OF CONFORMITY

The undersigned, representing the following manufacturer

PIUSI S.p.A.
46029 Suzzara (Mantova) Italy

CERTIFIES

that the equipment described below:

description: **DIESEL FUEL DISPENSER**
model: **MC BOX**

complies with the following directives:

2006/95/CE Low-Voltage Directive (and subsequent amendments)
2004/108/CE Electromagnetic Compatibility (and subsequent amendments)

Suzzara, 01/11/2008



Otto Varini, Chairman

The MC BOX dispensing units described in this manual are for professional use only.

B FIRST AID RULES



Persons who have ingested toxic liquids.

Whenever fuel has been swallowed, do not induce vomiting, but have the injured person drink large quantities of milk or water.



Persons who have suffered electric shock.

Disconnect the power source, or use a dry insulator to protect yourself while you move the injured person away from any electrical conductor.

Avoid touching the injured person with your bare hands until he is far away from any conductor.

Immediately call for help from qualified and trained personnel.

IN ALL CASES, SEEK MEDICAL ATTENTION IMMEDIATELY

C GENERAL

MC BOX Electronic Panels are designed for the private distribution of fuel (or other liquids).

All of the models in the series are characterised by the same form for which the MC BOX is known: a solid metal structure, high-accuracy measurements in the dispensed product and PC software that is designed for simplicity.

This electronic panel allows you to control and monitor private use fuel consumption via a fuel dispenser with pump and flow meter.

The MC system consists of a multi-user panel, dedicated software and the option to connect to a PC.

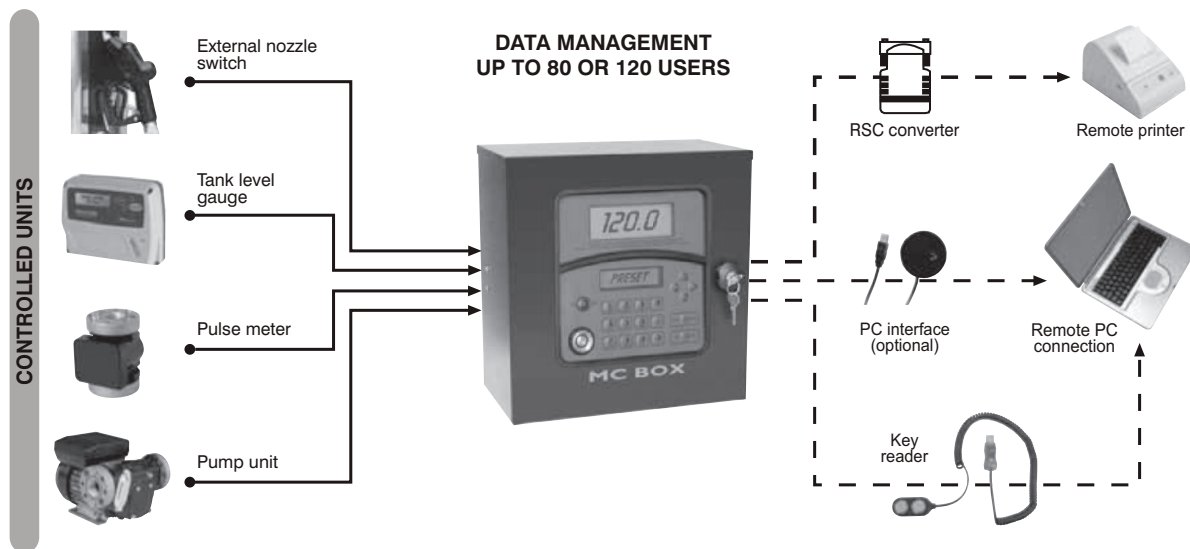

The MC BOX System has the ability to:

- Switch the pump on;
- Recognise authorised users;
- Preset the dispense quantity;
- Manage the pulse meter;
- Manage an external level switch that turns off the pump in the event of minimum flow level;
- Operate an external nozzle switch;
- Connect directly to a PC;
- Connect to an external printer

The panel is easy to install and is adequately protected. The wiring connections can be easily accessed.

The group can also be supplied with a meter, to be installed together with the pump.

Specifications

Panel with dual display, keyboard and i-button reader.

The electric box can be opened, allowing easy access to the wiring.

Maximum power supply: 6.5 amps.

Optional

- PC Software with dedicated RS converter or i-button reader to export data.
- I-button keys for users.
- High-accuracy oval gear flow meters.

Performance

- 80 or 120-user capacity (depending on model), managed via password or i-button key.
- Total consumption calculation for defined periods for each user.
- Local memory that can store data until the last 255 dispenses.
- Vehicle identification and mileage tracking option.
- Dispensing date and time control.
- Dedicated software that allows you to print dispense data for each user.
- Ability to manage up to 16 control panels with one single software.
- Key reader with USB plug for exporting data.
- RS converter with USB plug for direct connection to the PC via cable (up to 1000 m).

D SAFETY INSTRUCTIONS

All the MC BOX models have been designed and built according to applicable EEC directives relating to essential safety and health requirements.

Page 4 of this manual shows a copy of the manufacturer's DECLARATION OF CONFORMITY.

D.1 SAFETY RULES



Permitted Uses.

The unit must always be used for the purpose intended. Follow the instructions listed in the chapter Instructions for Use.



Electrical Precautions.

There are dangerously high voltages inside the unit. Only qualified and authorized technical personnel are allowed to open the fuel unit.



Service.

Service of the dispenser must be performed by qualified personnel.

OLD

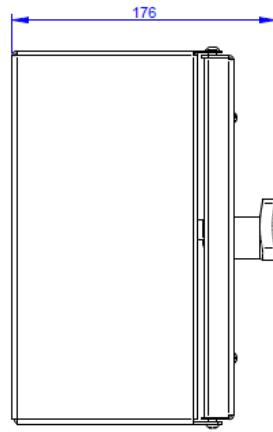
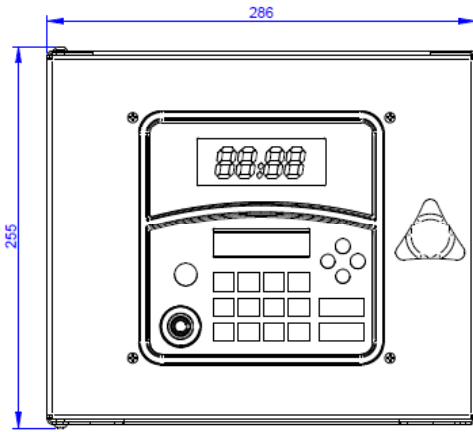

OLD

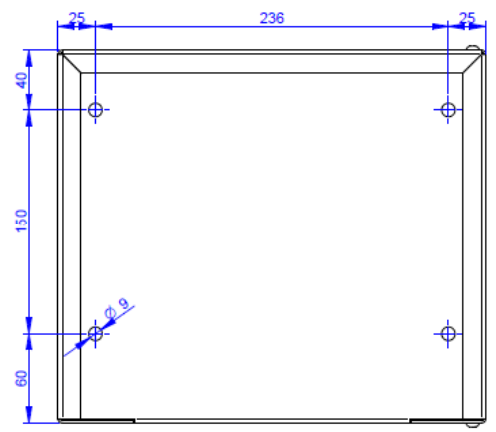

NEW

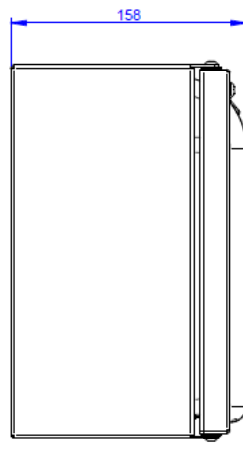
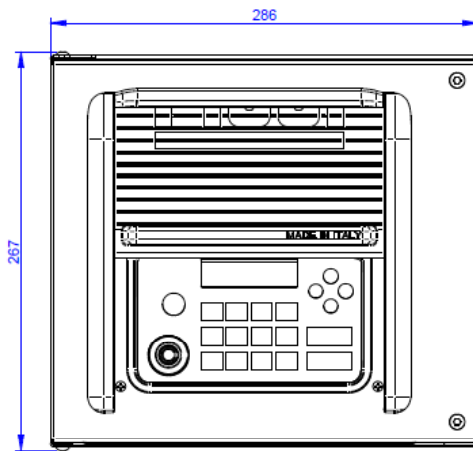

NEW

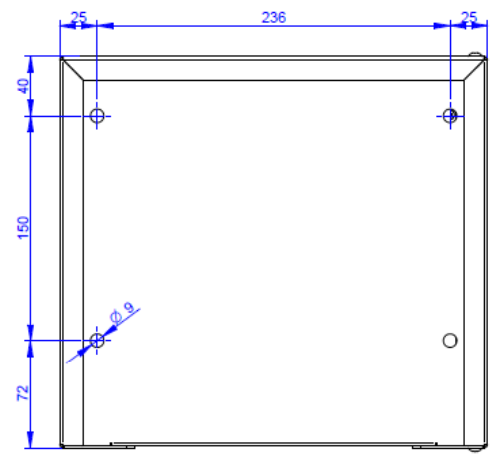

D.2 TRANSPORT, HANDLING AND UNPACKING

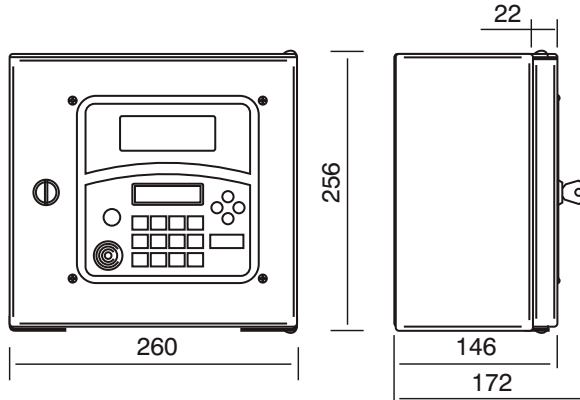

MC BOX is shipped inside stackable cardboard packaging.

DIMENSIONS OF PACKAGING: h=400 mm/
l =290 mm/
p=200 mm

TOTAL WEIGHT: 5.386 Kg

WEIGHT OF PACKAGING: 0.482 Kg

When the machine is not used, whether it is packed or unpacked, it must be stored in a place protected from the weather (rain, damp, sun, etc.) and from dust.

To remove the cardboard packaging, use a pair of scissors or cutters, being careful not to damage the appliance. Fully open the packaging and take out the MC BOX so that it can be taken to the place of final installation.

Packaging parts (cardboard, wood, cellophane, etc...) must be placed in specific containers and not left lying around or within reach of children, as these represent a potential risk hazard.

They must be disposed of according to the regulations applicable in the country of use.

Check the integrity of the machine by making sure the shipped parts are not damaged in any way that could affect safety and operation. In case of any doubts, do not start the appliance but contact the manufacturer's after-sales service.

D.3 DISPOSAL

Should the device be demolished, its parts and components should be entrusted to a firm that specialises in the disposal and recycling of industrial waste. Please note:

DISPOSAL OF PACKING MATERIAL:

the packaging is made of biodegradable cardboard and can be sent to companies for the normal recovery of cellulose-based packaging.

DISPOSAL OF METAL COMPONENTS:

metal parts, whether paint-finished or in stainless steel, can be consigned to scrap metal collectors.

DISPOSAL OF ELECTRIC AND ELECTRONIC COMPONENTS:

these have to be disposed by companies that are specialised in the disposal of electronic components, in accordance with the instructions of 2002/96/EC (see text of Directive below).

INFORMATION REGARDING THE ENVIRONMENT FOR CLIENTS RESIDING WITHIN THE EUROPEAN UNION:



European Directive 2002/96/EC requires that all equipment marked with this symbol on the product and/or packaging not be disposed of together with non-differentiated urban waste. The symbol indicates that this product should be disposed of separately from regular household waste streams.

It is the responsibility of the owner to dispose of these products as well as other electric or electronic equipment by means of the specific refuse collection structures indicated by the government or the local governing authorities.

DISPOSAL OF OTHER PARTS:

Other components, such as pipes, rubber gaskets, plastic parts and wires, must be disposed of by companies specialising in the disposal of industrial waste.

E USING AND LOOKING AFTER THE MANUALS

This manual is common to all MC box models and illustrates the main characteristics of the various models, providing information on:

- electrical and mechanical installation
- first start up operations
- daily use

This manual DOES NOT cover other aspects such as:

- configuration and operation of the Control system

For these aspects, refer to the specific manuals which accompany each station model.

For the installer's convenience, all supplied manuals are grouped together in an envelope. This collection of manuals represents an integral and essential part of the product and, according to the provisions of directive EEC 89/392, must be given to operators and maintenance staff in order to comply with the obligations relating to training/information referred to in directive EEC 89/391.

Carefully read the instructions contained in these manuals, as these are most important for installation safety, operation and maintenance.

The manufacturer shall not be responsible for damage caused to persons, to property or to the product that derive from improper use.

Look after this manual carefully in a place protected from damp, heat, dust, oils, greases, etc., as it will be useful for future reference and consultation. Do not remove, tear or amend any parts of the manual for any reason. In case of loss or damage, ask the manufacturer for a copy, quoting the manual code.

This manual must always remain with the machine; in the event of the machine being sold, it must be given to the new user.

WARNING

The company reserves the right to change MC BOX features and specifications at any time.

E.1 IDENTIFICATION PLATE

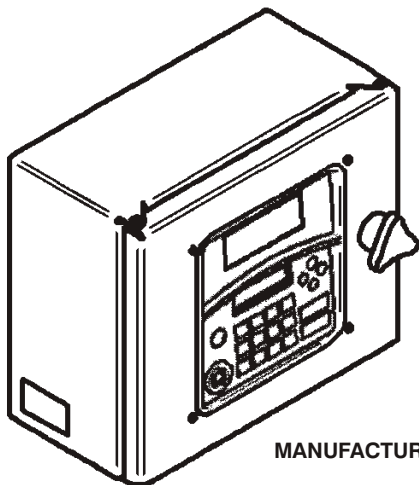

The MC BOX has an identification plate that reads:

- Model
- Serial number / Year of manufacture
- Technical Specifications
- CE mark

MANUFACTURER —

SERIAL NUMBER —

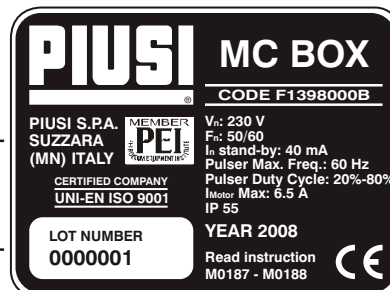

— PRODUCT NAME

— PRODUCT CODE
(see table)

— TECHNICAL
SPECIFICATIONS
(see table)

— YEAR OF MANUFACTURE

— “CE” MARK

	MC BOX 230 Vac - 50/60 Hz 80 user	MC BOX 230 Vac - 50/60 Hz 120 user	MC BOX 110 Vac - 50/60 Hz	MC BOX 12 Vdc	MC BOX 24 Vdc
Client reference code	F1398000B	F1398005A	F1398003A	F1398001A	F1398002A
Description	MC BOX 230V 80 USER	MC BOX 230V 120 USER	MC BOX 110V 120 USER	MC BOX 12V 120 USER	MC BOX 24V 120 USER
Nominal power supply (Voltage)	230 Vac	230 Vac	110 Vac	12 Vdc	24 Vdc
Nominal frequency (Hz)	50/60 Hz	50/60 Hz	50/60 Hz		
Nominal current consumption in stand-by mode at 25°C ambient temperature	40 mA	40 mA	80 mA	150 mA	75 mA
Power supply fuse on electronic board	100 mA T (Rit.)	100 mA T (Rit.)	200 mA T (Rit.)	1 A T (Rit.)	1 A T (Rit.)
Max. motor current (A)	6.5 A	6.5 A	7.0 A	50 A	25 A
Motor fuse	8 A T (Rit.)	8 A T (Rit.)	8 A T (Rit.)	Sized according to the power of the connected DC 12V motor, but must NOT exceed 60 A (automotive)	Sized according to the power of the connected DC 24V motor, but must NOT exceed 30 A (automotive)

WARNING

Before installing, always make sure the dispenser model is correct and suitable for the available power supply (voltage / frequency).

F DESCRIPTION OF MAIN PARTS

The MC BOX is designed for the private dispensing of fuel.

Recognised for their ease of use and maximum safety, MC BOX dispensers are reliable, high-performing, quick to install and ready-to-use.

Equipment and features are:

- Sturdy, lockable metal box with hinged door;
- Electronic Control Panel with:
 - Dual display
 - Membrane keyboard
 - Recognition and access control system with electronic key, allowing for a simple man-machine interface.

The electronic panel is also equipped with other out-facing interfaces, such as:

- Pump ignition control
- Nozzle contact input command
- Level contact input command
- RS485 output for PC connection
(subject to software installation and available drivers)

F.1 CONTROL SYSTEM

The electronic control system -MC- ensures the dispenser can only be used by authorised personnel.

All the data relating to each dispensing operation are stored and can be transferred to a PC (optional).

G TECHNICAL SPECIFICATIONS

G.1 PERMITTED USES

Implementation of a fluid dispensing system, intended for private use, not subject to special regulations (e.g. ATEX) for potentially explosive environments.

G.2 CONTROL SYSTEM PERFORMANCE

The performance of the MC control system is detailed in the M0187 manual supplied together with the MC BOX.

G.3 METERING PRECISION

Mainly influenced by the pulsation type used.

For further details, please refer to the specific user manual for the pulsation type used.

G.4 ABSORBED POWER

See table, paragraph E.1.

The maximum acceptable variations from the electrical parameters are:

- Voltage +/-10 % for AC versions
- Voltage +/-15 % for battery-operated DC versions
- Frequency +/-1% (+/-2% for short periods) (for AC versions)

H INSTALLATION

H.1 GENERAL

The MC BOX can be installed outdoors. Nevertheless, it is advisable to locate it under the shelter of a roof to ensure the dispenser's longevity and provide greater comfort during refueling in the event of bad weather.

The installation of the dispenser must be carried out by skilled personnel and performed according to the instructions provided in this chapter.

H.2 ELECTRICAL CONNECTIONS

The power connections must be workmanlike performed by skilled personnel, in strict compliance with the laws applicable in the country of installation and with the instructions on the wiring diagrams in this manual.

WARNING

- *The MC BOX Electronic Panel does NOT come with protective switches; it is therefore mandatory that the MC BOX be installed with an electrical panel that is suitable to the individual MC BOX and has a differential power switch or, at the very least, a fast-access device such as a socket/plug, to be used in the event of anomalies;*
- *All the electronic components found within the MC BOX container have been pre-wired and tested at the factory; as such, it is NEVER necessary to have the MC BOX opened by the person who installed it or the plant operator, unless the fuse protection on the I/O card needs to be replaced;*
- *The installer should carry out a plug/socket connection for a quick sectioning of the electric system in case of failures.*

The MC BOX is equipped with 3 junction boxes. These can easily be accessed by opening the door to where the screw terminals for the external cable connections are located.

WARNING

Before accessing the electrical parts, be sure that you have disconnected all of the general switches that power the device.

The connections that need to be made vary according to the model (AC or DC):

AC Versions:

Inputs	Outputs	Note
AC mains supply	AC motor power the same voltage as the mains	Voltage: 230Vac or 110Vac, depending on the maximum power of the pluggable motors: <ul style="list-style-type: none"> • 230Vac version = 1400 W • 110Vac version = 750 W
Nozzle contact: clean contact: Open with nozzle replaced and Closed when nozzle dispensing		
Level contact: clean contact: Open with nozzle in normal conditions and Closed below the minimum flow level		
Pulse meter input: clean contact or Open Collector output signal, with 60 Hz maximum frequency and between 20% and 80% duty cycle		
	The RS 485 data line to the PC (optional)	

DC Versions:

Inputs	Outputs	Note
DC Power Supply	DC motor power is the same as the supply voltage	Voltage: 12Vdc or 24Vac, depending on the maximum power of the pluggable motors: • 12Vdc version = 600 W • 24Vdc version = 600 W
Power input WITH IGNITION ON. Given the DC systems' high power absorption, the motor should be powered while the battery is being recharged		By removing a jumper and inserting the "in ignition" contact in its place, the electronics can be powered only when the vehicle is switched on
Nozzle contact: clean contact: Open with nozzle replaced and Closed when nozzle dispensing		
Level contact: clean contact: Open with nozzle in normal conditions and Closed below the minimum flow level		
Pulse meter input: clean contact or Open Collector output signal, with 60 Hz maximum frequency and between 20% and 80% duty cycle		
	The RS 485 data line to the PC (optional)	

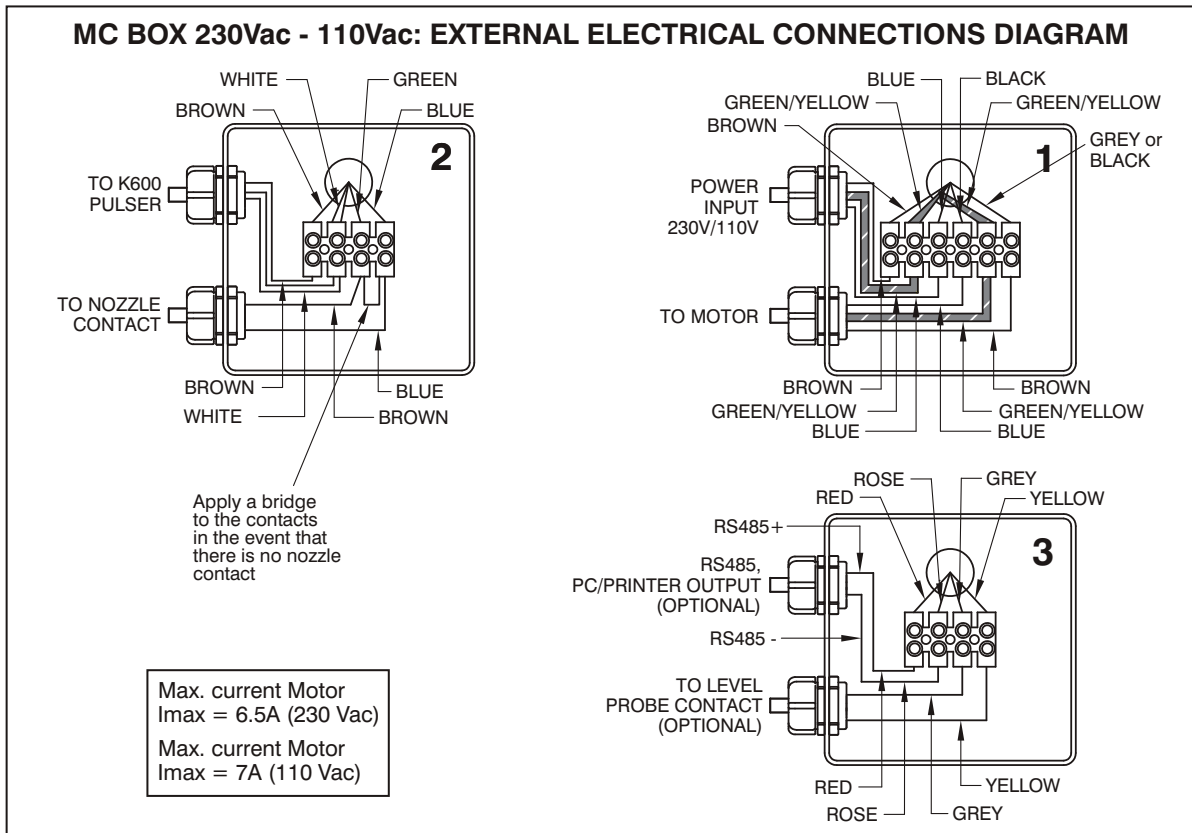

MC BOX 12Vdc - 24Vdc: EXTERNAL ELECTRICAL CONNECTIONS DIAGRAM

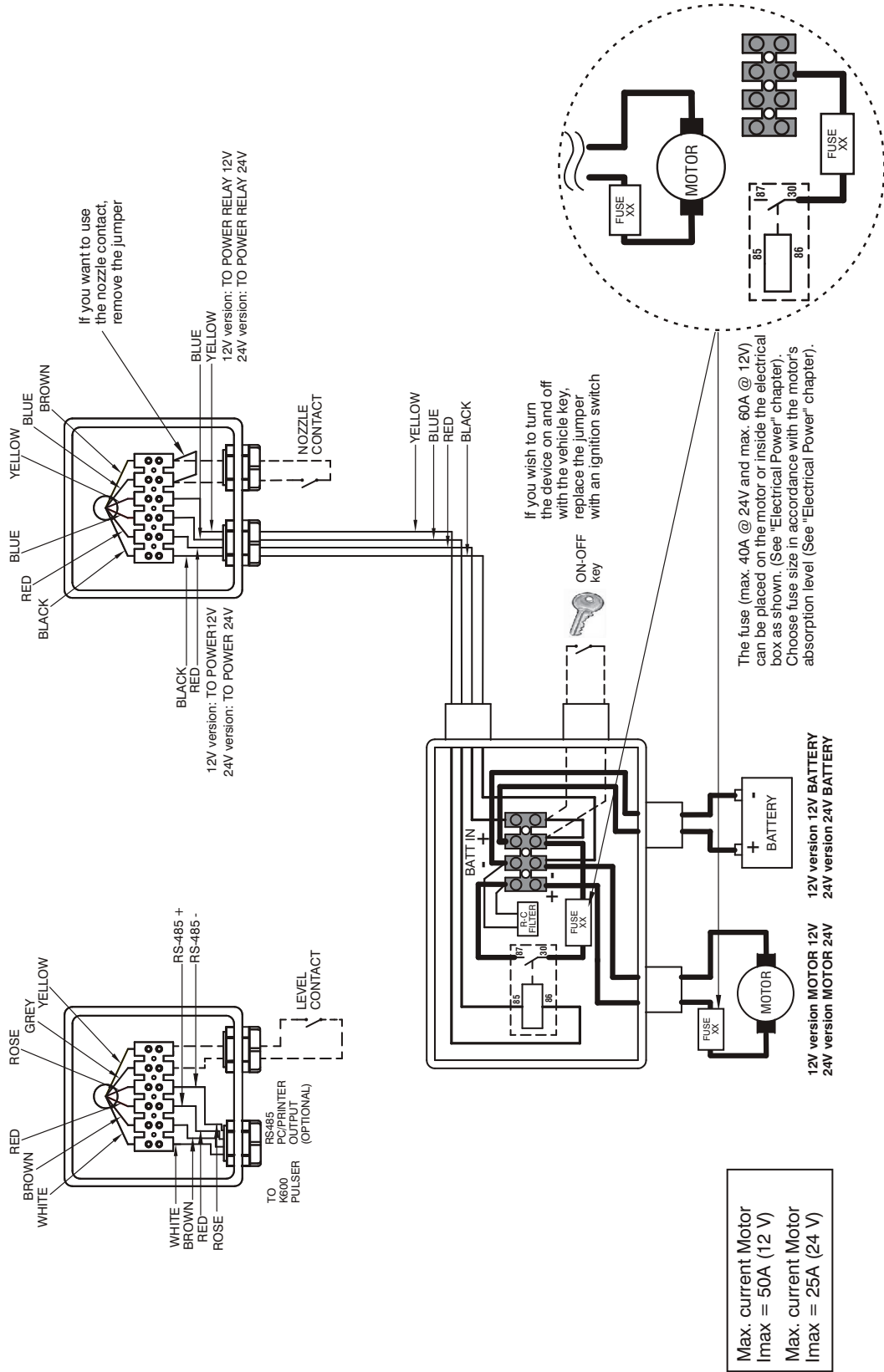

**MC BOX 230Vac - 110Vac:
INTERNAL ELECTRICAL
CONNECTIONS DIAGRAM**

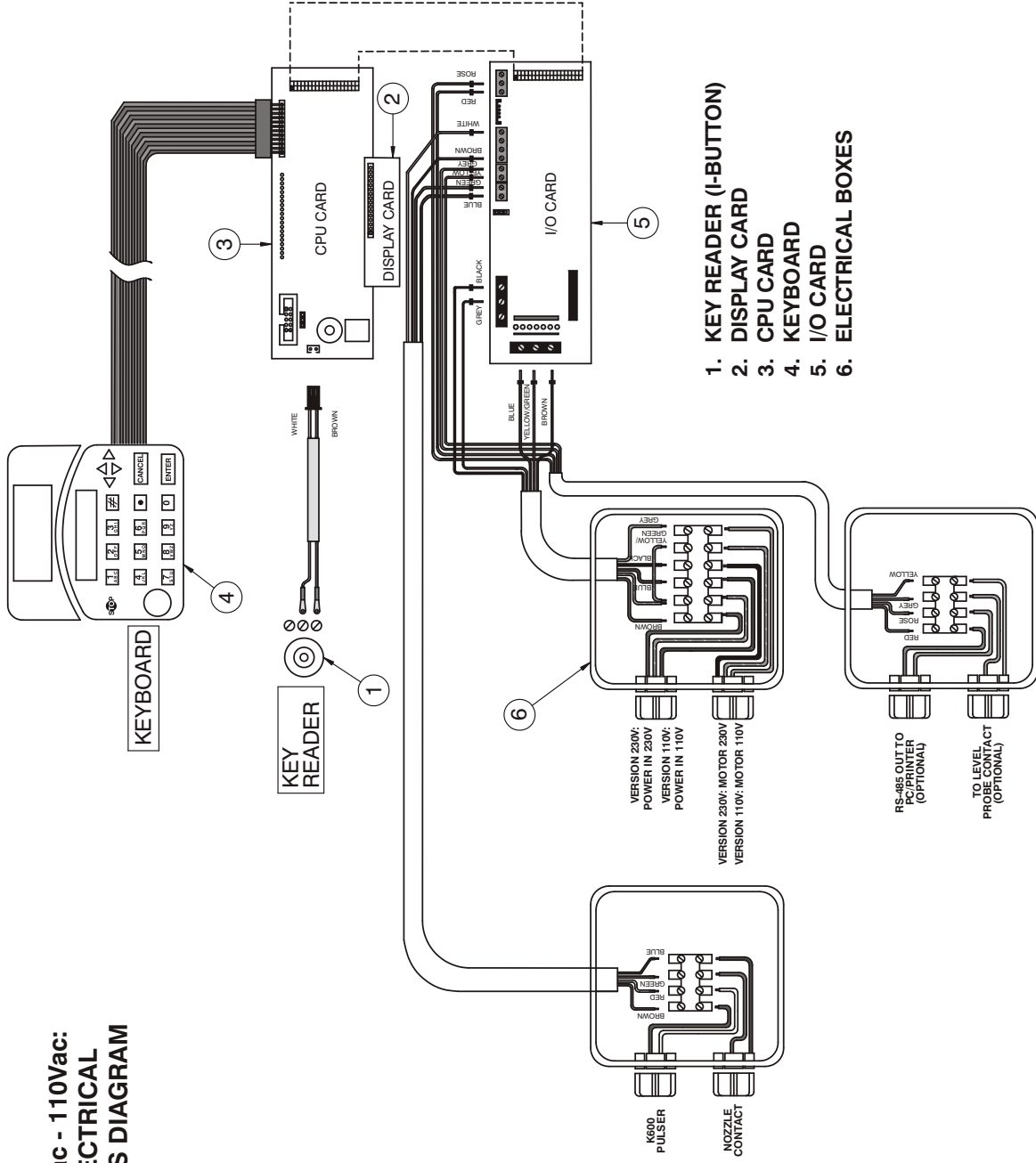

MC BOX 12Vdc / 24Vdc: INTERNAL ELECTRICAL CONNECTIONS DIAGRAM

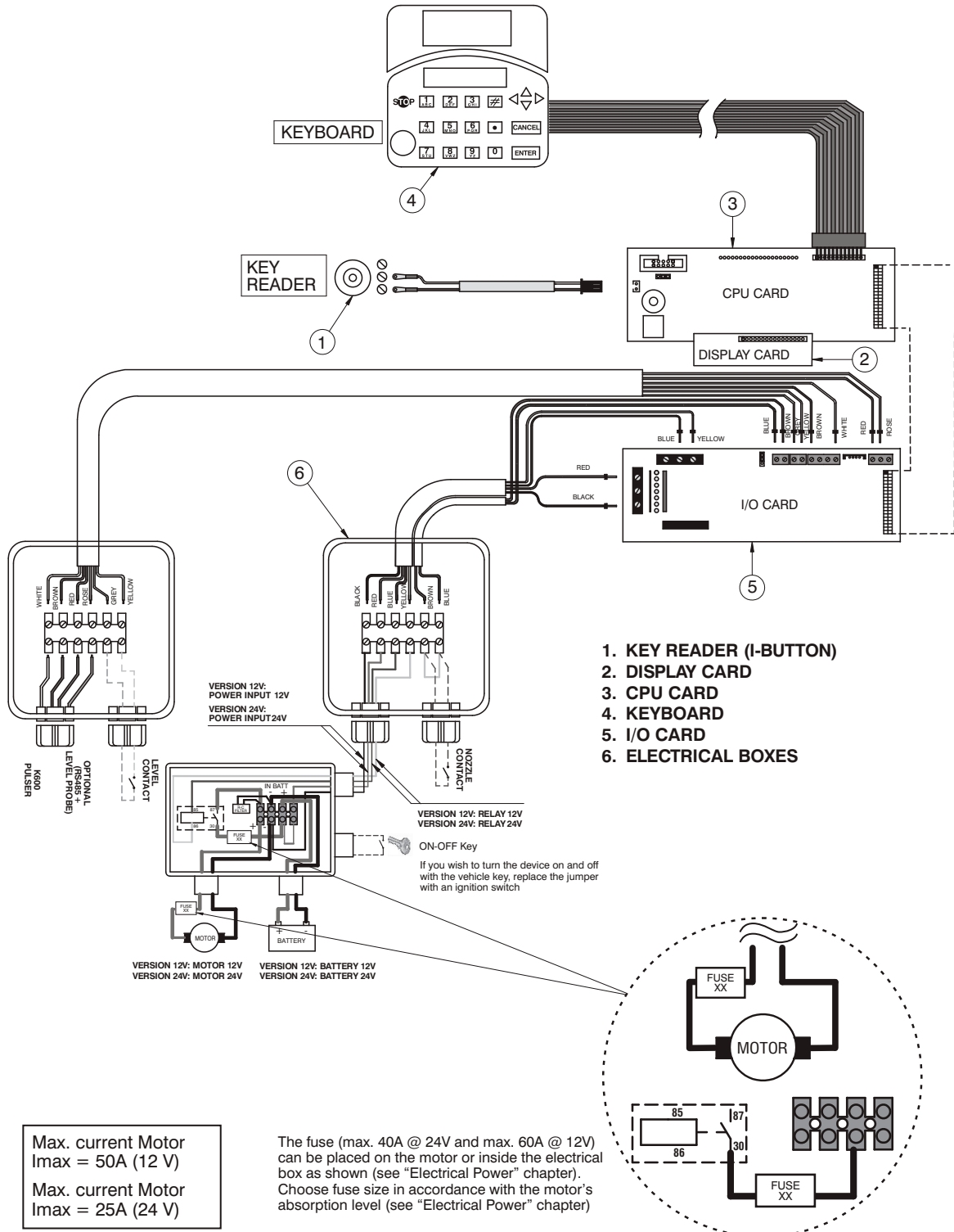

I COMMISSIONING

To correctly commission the MC BOX the sequence of operations indicated below must be followed and the MC control system functions must be known (see attached manual).

I.1 ELECTRICAL POWER SUPPLY

Once the power connections have been made, the MC BOX can be energised by means of the master switch to be fitted by the installer on the upstream line. Switching on of the MC system will be indicated by the lighting up of the two backlit LCDs fitted on the front.

NOTE:

In the event of continuous current power supply (DC), a fuse size that is appropriate to the DC motor's absorption level should be introduced to the motor power line.

For example:

- If the connected motor is one that absorbs 10A max then a 12A delay fuse should be inserted.
- If, however, the motor absorbs 50A max, then a 60A delay fuse should be inserted.

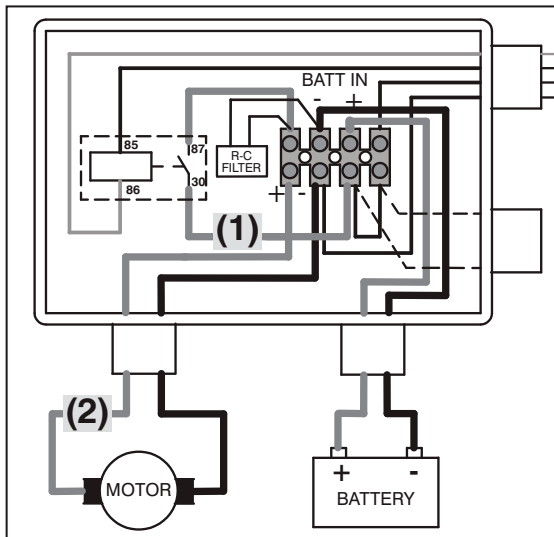

- If the fuse is small, it can be fitted along the cable inside the junction box, in position (1) (see illustration)
- If, however, the fuse is very big (e.g. 60A) and cannot physically fit inside the box, then it can be inserted along the motor's power supply cable in position (2) (see illustration)

I.2 STATION CONFIGURATION

Every MC BOX station can be adapted to the specific requirements of the station manager. To do this the MC control system must be CONFIGURED.

WARNING

**MC configuration is crucial and must be done by skilled personnel.
To perform this operation, the MC manual must be carefully and thoroughly read.**

After completing configuration, user PIN CODES can be assigned to the persons charged with using MC BOX, in accordance with the detailed information in the MC manual.

I.3 DISENGAGING THE “MC” SYSTEM

All the MC BOX functions are controlled by the MC control system.

The MC system can nevertheless be disengaged for any startup or maintenance activities requiring repeated pump starting.

In these case, it is often convenient to simplify pump startup by not having to enter any code and record any dispensing data.

To do this, a JUMPER has been fitted on the card that permits switching from AUTOMATIC mode (code request to access dispensing) to MANUAL mode (no code request).

WARNING

The jumper is only accessible by opening the front panel and is positioned as shown in the photo.

In this operating mode, MC does not record any data relating to performed dispensing operations.

Before accessing this jumper, the voltage must be removed.

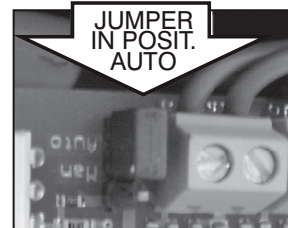
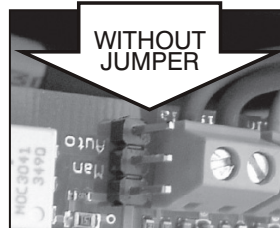
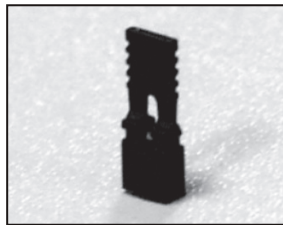
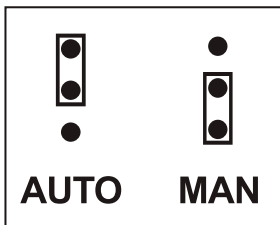

WARNING

Before accessing the electrical parts, be sure that you have disconnected all of the general switches that power the device.

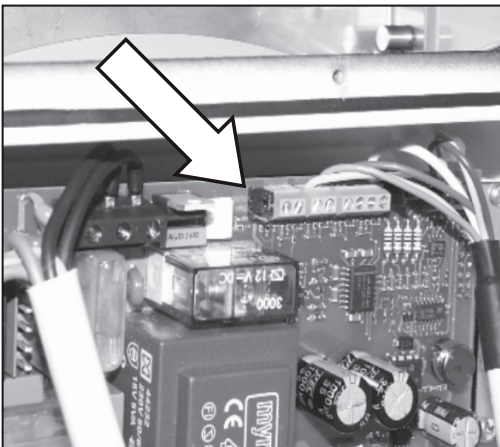

In MANUAL mode:

- The MC's LCD may be switched off (only the backlight is clearly visible) or you may continue to see the indication that was present at the time of transition from AUTO to MAN.
- No PIN CODE is required to activate the pump; the pump starts when the dispenser nozzle is removed from its lodging and stops when it is put back (naturally this is in the event that the "nozzle contact" function is used).
- The amount dispensed is not shown in any way.

I.4 METER CALIBRATION

Before using the MC BOX station, check the METER ACCURACY.

For this purpose, proceed as follows:

- Enter a previously enabled USER PIN code;
- Run the fuel into a calibrated container;
- Compare the quantity of dispensed diesel fuel using a calibrated container.

If accuracy is NOT satisfactory, proceed to CALIBRATE THE METER according to the instructions in the specific manual.

WARNING

To correctly check accuracy, always keep to the following instructions:

- *Use a precision sample container, featuring a graduated scale, with a capacity of at least 20 litres.*
- *Before making the check, always make sure you have eliminated all the air from the system and then run the fuel until a full and regular flow is achieved.*
- *Dispense continuously at MC BOX maximum flow rate.*
- *Stop the flow by quickly closing the nozzle.*
- *Reach the graduated area of the sample container, avoiding prolonged dispensing at low flow rate, but rather performing short dispensing operations at maximum flow rate.*
- *Compare the reading provided by the container, with that provided by MC BOX, after waiting for all the froth to disappear*

WARNING

Differences of up to 1/10 of a litre affecting the dispensing of 20 litres of fluid fall within the guaranteed precision of +/- 0,5%.

L EVERY DAY USE

Thanks to the MC control system, all the MC BOX models provide access to authorised users only.

MC acknowledges User authorisation by means of two alternative systems:

- The entering of a 4-figure SECRET CODE (PIN CODE)
- The fitting of an electronic key (OPTIONAL)

WARNING

All the users to whom a PIN CODE is assigned must be adequately instructed and be at least acquainted with the contents of this chapter.

The configuration of the MC system permits requiring the User to enter further optional data (vehicle licence plate, mileage, quantity to be dispensed).
For details, see the MC control system manual.

In the event that these options are not set, MC will recognise an activated PIN CODE and, once the nozzle contact (if applicable) has been closed, the pump is enabled, allowing it to dispense

WARNING

***Such enabling does not result in immediate pump startup.
The pump is in fact controlled by a switch (positioned in the nozzle seat) operated by the user.***

The pump will start (if previously enabled) just as soon as the control lever is moved to ON position, while it switches off as soon as the control lever is moved to OFF position.

No further manual operation is required to start or stop the pump.

L.1 FUEL DISPENSING

WARNING

Fuel MUST ONLY be dispensed under the careful control of the User.

In the case of the simplest configuration (no optional data required), the fuel dispensing procedure is the following:

- Insert PIN CODE
(or apply the electronic key)

If the MC recognises the activated PIN (or key), a “GOOD MORNING MANAGER / USER” message is displayed and the pump enabled.

For details on dispensing options, please refer to the M0187 manual.



M ROUTINE MAINTENANCE**M.1 “MC” CONTROL SYSTEM**

The MC system is maintenance free.

To control it however, refer to the dedicated M0187 manual provided.

M.2 TROUBLESHOOTING

PROBLEM	POSSIBLE CAUSES	SOLUTIONS
The MC BOX does not switch on	Power supply has failed due to: <ul style="list-style-type: none"> • The power leads being connected incorrectly • The upstream circuit switch being in the OFF position • The power supply fuse being interrupted • For DC versions: vehicle key in the OFF position (if the “ignition on” power supply option has been adopted) 	<ul style="list-style-type: none"> • Check connections • Ensure disconnect switch is in the ON position • Check fuse • Turn the vehicle key to the ON position
The MC BOX turns on and the displays light up but no words appear The MC BOX turns on and the displays light up but the words that appear are irregular and the system does not respond to any commands	AUTO/MAN jumper in the MAN. position	Put the jumper to the AUTO position
The system does not recognise the “USER” with PIN CODE or Electronic key	The user has not yet been configured by the system MANAGER	The system MANAGER sets up a New User
	The key has not been linked to the User by the system MANAGER	The system MANAGER links the key to the User
	The keyboard is damaged and does not insert the data properly	Change keyboard (contact technical support)
	The electronic key is damaged and is no longer recognised by the system	Change electronic key (contact technical support)

PROBLEM	POSSIBLE CAUSES	SOLUTIONS
The MOTOR will NOT START	It has not been connected properly to the set terminals	Check connections
	Action not permitted by nozzle contact	Check how the nozzle contact option has been set (YES/NO) and the status of the relevant jumper
DOES NOT COUNT when dispensing	The Pulser that emits the count signals has not been connected properly	Verificare collegamenti
	The Pulser that emits the count signals is NOT compatible with the electronics	An incoming electronic signal, namely "clean contact" or "OpenCollector", should be received. If the input signal is an incompatible voltage signal, the electronic board is likely to be damaged, in addition to the malfunction
The count is INACCURATE	The system is NOT calibrated	Calibrate the system according to the procedure
The count remains INACCURATE even after calibration, or it is accurate but only for low flow rates	The signal sent by the Pulser is outside the acceptable electronic ranges	The maximum pulsation frequency must be 70 Hz and between 20% and 80% duty cycle. The system does not process received data correctly outside the acceptable electronic ranges. The system must adapted to fit within the correct ranges, possibly by interposing other electronic interface devices (please contact Technical Support for options)
It DOES NOT COMMUNICATE with the PC	The RS485 connection is not correct	Check the connections
	The driver on the PC is not installed properly or the version is not compatible with the PC's Operating System	Check the versions of the drivers and the Operating System. Contact Technical Assistance
	The RS232 or USB converter is damaged	Try with a different converter: if the problem disappears, replace the converter
	The PC's USB or RS232 port is damaged	Try a different port or try it on a different PC to check the rest of the device: if it works on another PC, then the problem is with the PC

N.1 CHECKING AND REPLACING FUSES

To check and replace contained fuses

- on the electronic boards
- and/or
- in the junction box (for DC versions):

- 1) Remove voltage from the device;
- 2) Open the door to the MC BOX with the special key;
- 3) Open the junction box that contains the motor fuse (DC only) for verification and possibly replacement;
- 4) Unscrew the metal back panel to access the electrical boards compartment;
- 5) Check the condition of the fuses and replace if necessary

MOTOR FUSES (AC Motors)

- 8 A T (Rit)

POWER FUSE

- 100 mA T (Rit)
for the 230V / 50 Hz version
- 200 mA T (Rit)
for the 110V / 60 Hz version
- 1 A T (Rit)
for versions DC 12 Vdc and 24 Vdc

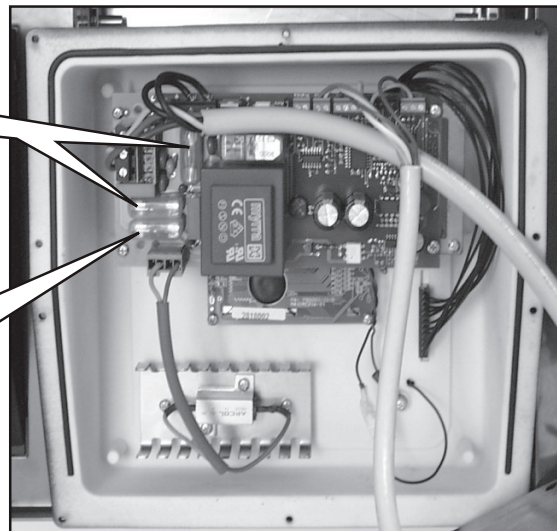

MOTOR FUSES (DC Motors)

- The fuse (max. 40A @ 24V and max. 60A @ 12V) can be placed on the motor or inside the electrical switch box (see "Electrical Power" chapter)
Choose fuse size in accordance with the motor's absorption level (see "Electrical Power" chapter).

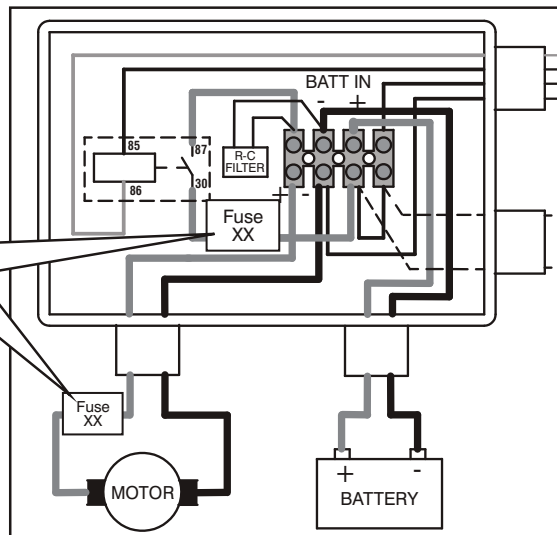

- 6) Shut down everything and restore power.

O MC BOX SPARE PARTS

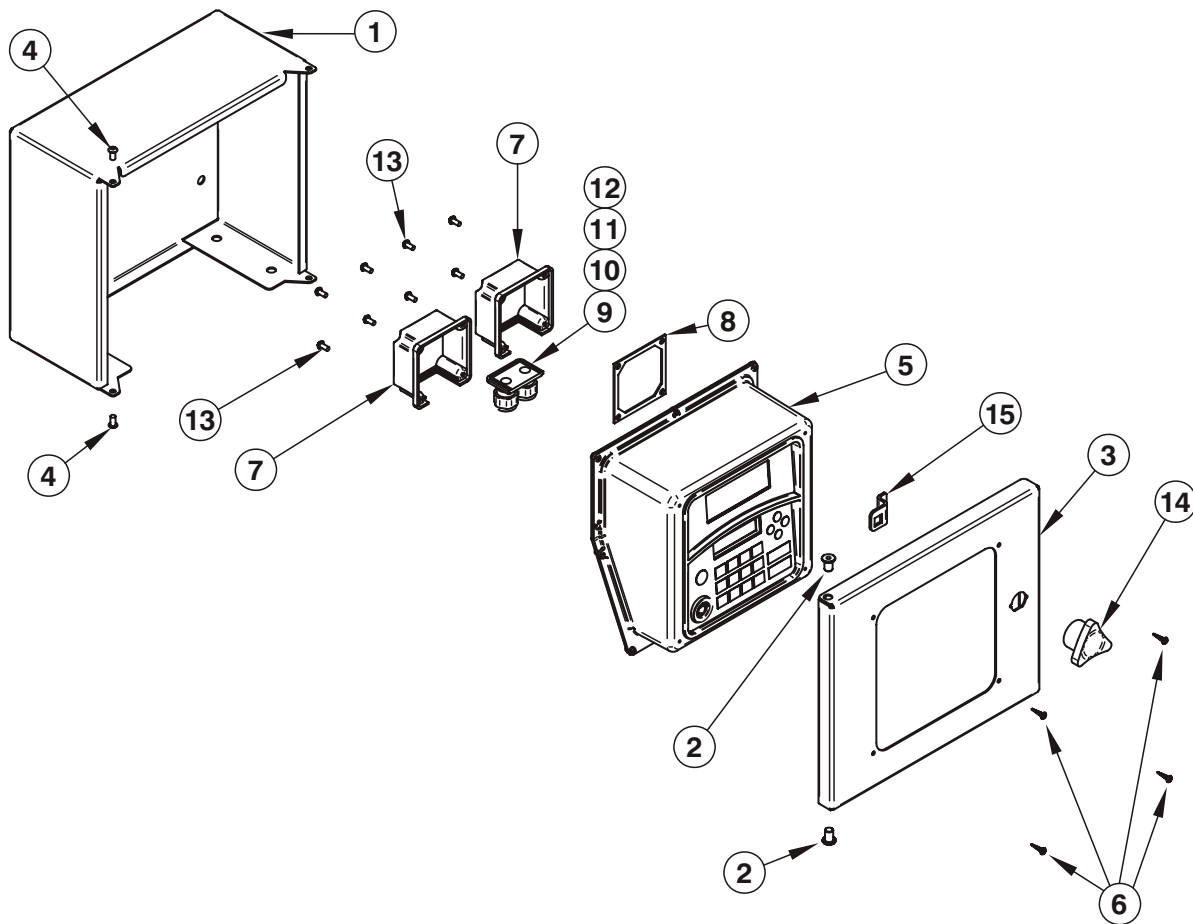

P MANUFACTURER AND SERVICE DATA

MANUFACTURER:	PIUSI S.p.A.
DOCUMENT TYPE:	General Description and Instructions for Its Installation, Activation, Use and Maintenance
EDITION:	Bullettin M0188 IT - Ed. 0
PRODUCT:	Diesel fuel dispenser for private use with meter
MODEL:	All the models of the MC BOX range, with single-phase/three-phase mechanical/electronic meter, with various voltages/frequencies
CONFORMITY:	CE Mark (see Declaration of conformity, page 4)
TECHNICAL SUPPORT:	Provided by the Service Departments of our Authorized Resellers

The information contained in this manual is provided by the Manufacturer, who reserves the right to make changes without prior notice

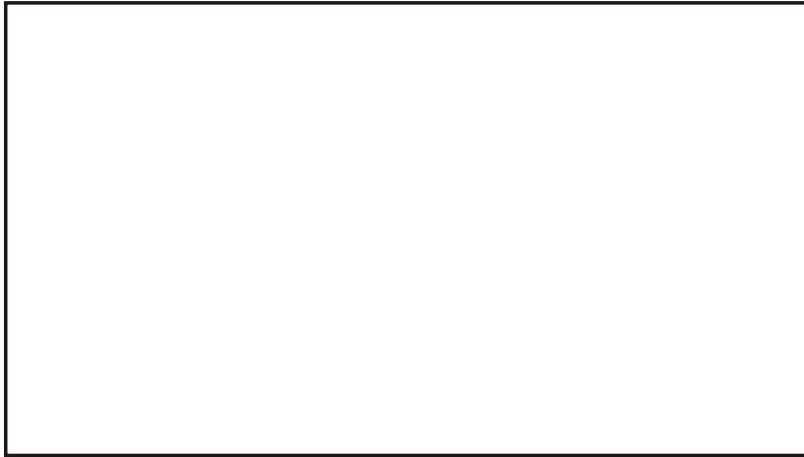

Authorized reseller's stamp



M0188 EN - Rev.0